

# LR431 LINEAR INTEGRATED CIRCUIT

## PROGRAMMABLE PRECISION REFERENCE

### DESCRIPTION

The LRC LR431 is a three-terminal adjustable regulator with a guaranteed thermal stability over applicable temperature ranges. The output voltage may be set to any value between  $V_{ref}$  (approximately 2.5V) and 36V with two external resistors. It provides very wide applications, including shunt regulator, series regulator, switching regulator, voltage reference and others.

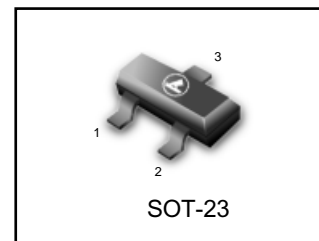

SOT-23 1: Ref; 2: Cathode; 3: Anode

### FEATURES

- Programmable output Voltage to 36V.
- Low dynamic output impedance  $0.2\Omega$
- Sink current capability of 1 to 100mA.
- Equivalent full-range temperature coefficient of 50ppm/°C typical for operation over full rated operating temperature range.

Pb-Free package is available

### BLOCK DIAGRAM

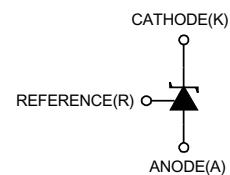
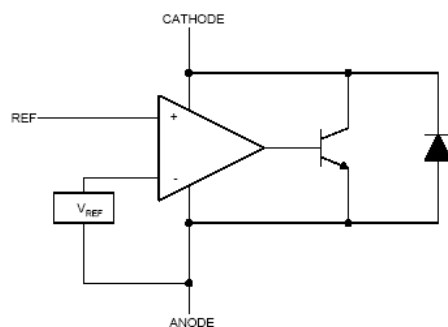

# LR431 LINEAR INTEGRATED CIRCUIT

**ABSOLUTE MAXIMUM RATINGS** (Operating temperature range applies unless otherwise specified)

PARAMETER	SYMBOL	VALUE	UNIT
Cathode Voltage	V <sub>K</sub> A	36	V
Cathode Current Range(Continuous)	I <sub>K</sub> A	-100 ~ +150	mA
Reference Input Current Range	I <sub>ref</sub>	-0.05 ~ +10	mA
Operating Junction Temperature	T <sub>j</sub>	150	°C
Operating Ambient Temperature	T <sub>opr</sub>	0 ~ +70 / -40 ~ +125	°C
Storage Temperature	T <sub>stg</sub>	-65 ~ +150	°C

**RECOMMENDED OPERATING CONDITIONS**

PARAMETER	SYMBOL	MIN	TYP	MAX	UNIT
Cathode Voltage	V <sub>K</sub> A	V <sub>REF</sub>		36	V
Cathode Current	I <sub>K</sub> A	1		100	mA

**ELECTRICAL CHARACTERISTICS** (T<sub>a</sub>=25°C, unless otherwise specified)

PARAMETER	SYMBOL	TEST CONDITIONS	MIN	TYP	MAX	UNIT
Reference Input Voltage *	V <sub>ref</sub>	V <sub>K</sub> A=V <sub>REF</sub> , I <sub>K</sub> A=10mA		2.50 2.495		V
Deviation of reference Input Voltage Over temperature(note 1)	ΔV <sub>ref</sub> /ΔT	V <sub>K</sub> A=V <sub>REF</sub> , I <sub>K</sub> A=10mA T <sub>MIN</sub> ≤T <sub>A</sub> ≤T <sub>MAX</sub>		4.5	17	mV
Ratio of Change in Reference Input Voltage to the Change in Cathode Voltage	ΔV <sub>ref</sub> /ΔV <sub>K</sub> A	I <sub>K</sub> A=10mA ΔV <sub>K</sub> A=10V~V <sub>REF</sub> ΔV <sub>K</sub> A=36V~10V		-1.0 -0.5	-2.7 -2.0	mV/V
Reference Input Current	I <sub>ref</sub>	I <sub>K</sub> A=10mA, R1=10kΩ, R2=∞		1.5	4	μA
Deviation of Reference Input Current Over Full Temperature Range	ΔI <sub>ref</sub> /ΔT	I <sub>K</sub> A=10mA, R1=10kΩ, R2=∞ T <sub>A</sub> =full Temperature		0.4	1.2	μA
Minimum Cathode Current for Regulation	I <sub>K</sub> A(min)	V <sub>K</sub> A=V <sub>REF</sub>		0.45	1.0	mA
Off-State Cathode Current	I <sub>K</sub> A(OFF)	V <sub>K</sub> A=36V, V <sub>REF</sub> =0		0.05	1.0	μA
Dynamic Impedance	Z <sub>K</sub> A	V <sub>K</sub> A=V <sub>REF</sub> , I <sub>K</sub> A=1 to 100mA f≤1.0kHz		0.15	0.5	Ω

\* CLASSIFICATION OF V<sub>ref</sub> AND PACKAGE

Type	RanK	Range(V)	Marking	Packa	T <sub>opr</sub>
LR431ALT1G	0.5%	2.487~2.512	RA	SOT-23	0~+70 °C
LR431BLT1G	1%	2.475~2.525	RB	SOT-23	0~+70 °C
LR431APLT1G	0.5%	2.482~2.507	RA1	SOT-23	0~+70 °C
LR431BPLT1G	1%	2.470~2.520	RB1	SOT-23	0~+70 °C
LR431ATLT1G	0.5%	2.487~2.512	RA2	SOT-23	-40~+125 °C
LR431BTLT1G	1%	2.475~2.525	RB2	SOT-23	-40~+125 °C
LR431APTTLT1G	0.5%	2.482~2.507	RA3	SOT-23	-40~+125 °C
LR431BP TTLT1G	1%	2.470~2.520	RB3	SOT-23	-40~+125 °C

# LR431 LINEAR INTEGRATED CIRCUIT

## TYPICAL PERFORMANCE CHARACTERISTICS

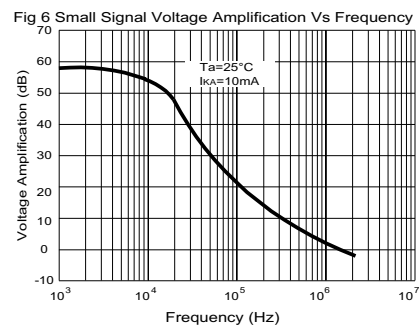
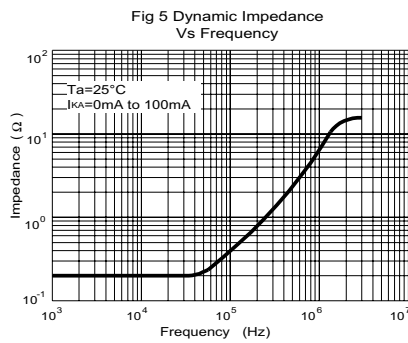
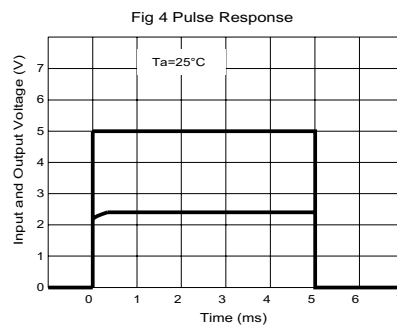
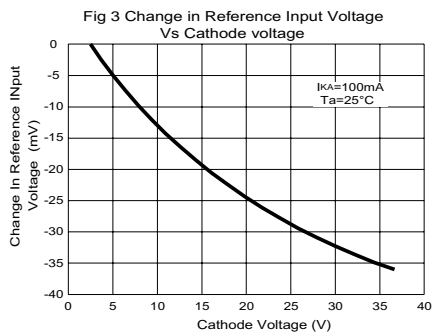
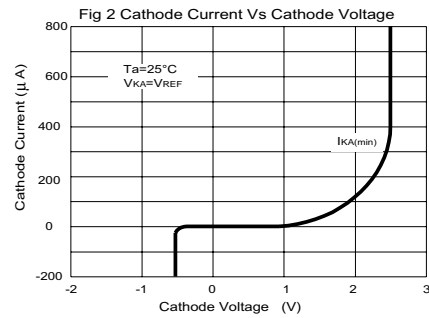
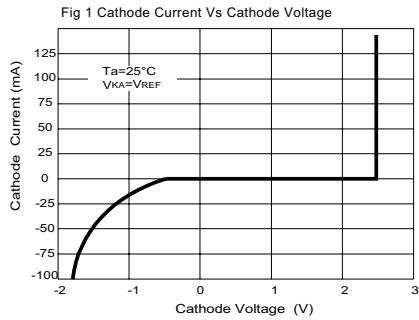

# LR431 LINEAR INTEGRATED CIRCUIT

## TEST CIRCUIT

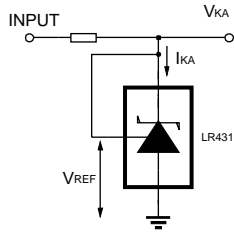

Fig 7 Test Circuit For  $V_{KA}=V_{REF}$

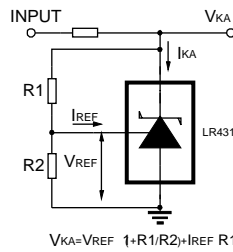

Fig 8 Test Circuit for  $V_{KA} \geq V_{REF}$

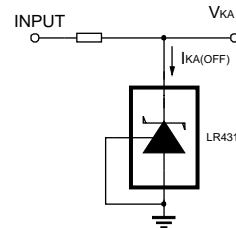

Fig 9 Test Circuit For  $I_{KA(OFF)}$

## APPLICATION CIRCUIT

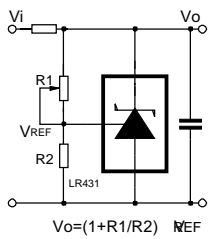

Fig 10 Shutdown Regulator

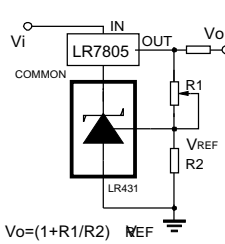

Fig 11 Output Control of a Three-Terminal Fixed Regulator

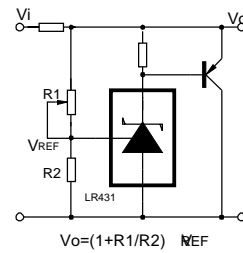

Fig 12 Higher-current Shunt Regulator

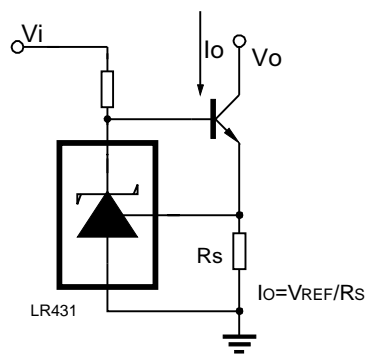

Fig 13 Constant-current Sink

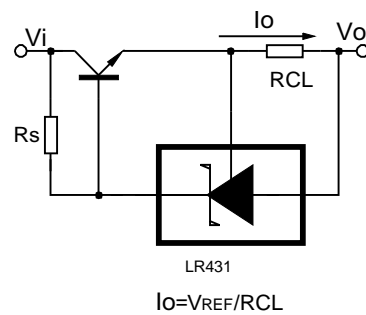
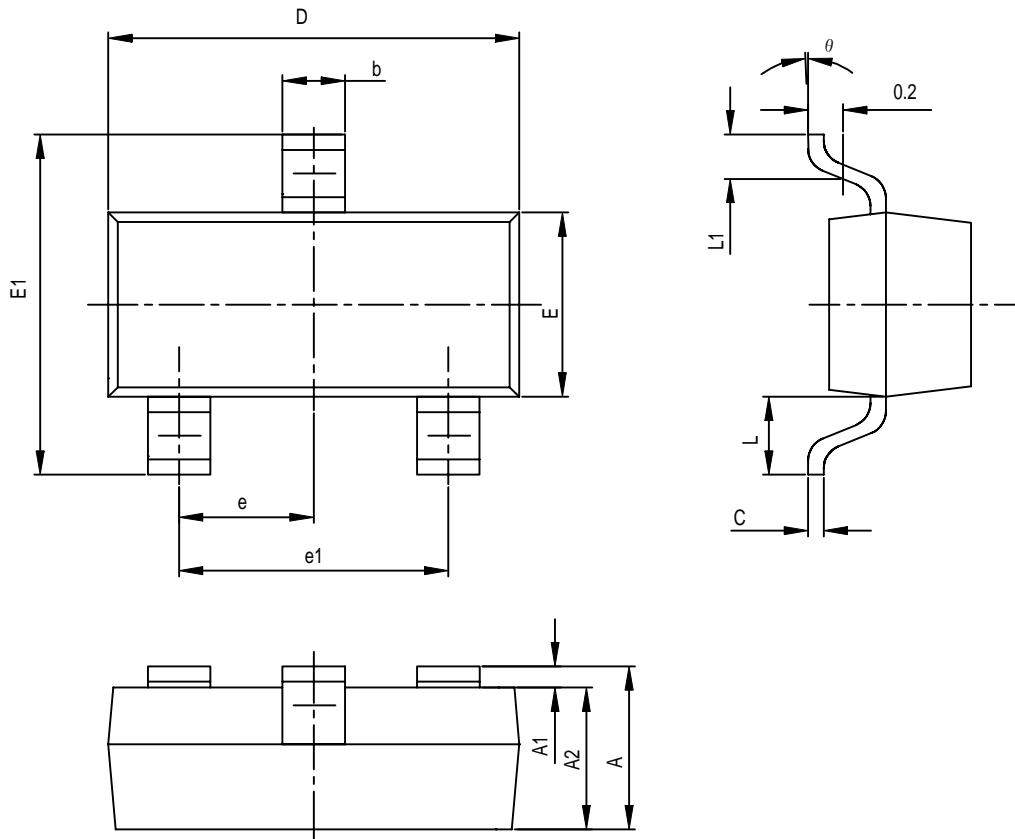

Fig 14 Current Limiting or Current Source

**SOT-23 PACKAGE OUTLINE DIMENSIONS**

Symbol	Dimensions In Millimeters		Dimensions In Inches	
	Min	Max	Min	Max
<b>A</b>	0.900	1.100	0.035	0.043
<b>A1</b>	0.000	0.100	0.000	0.004
<b>A2</b>	0.900	1.000	0.035	0.039
<b>b</b>	0.300	0.500	0.012	0.020
<b>c</b>	0.080	0.150	0.003	0.006
<b>D</b>	2.800	3.100	0.110	0.118
<b>E</b>	1.200	1.610	0.047	0.055
<b>E1</b>	2.250	2.550	0.089	0.100
<b>e</b>	0.950TPY		0.037TPY	
<b>e1</b>	1.800	2.000	0.071	0.079
<b>L</b>	0.550REF		0.022REF	
<b>L1</b>	0.300	0.500	0.012	0.020
<b>θ</b>	0°	8°	0°	8°