

**MCE1012E90FBP (Chip Common Mode Filter plus ESD function)
Engineering Specification**



Features and Application

- Powerful components with composite co-fired material to solve EMI problem for high speed differential signal transmission line as USB, and LVDS, without distortion to high speed signal transmission.
- Common mode filter plus ESD function.
- MIPI, MHL serial interface in mobile device.

1. PRODUCT DETAIL

Part No.	Imp. Com. (Ω)±25% @100MHz	DCR Max. (Ω)	Rated Current Max.(mA)	Working Voltage (V)	Insulation Resistance Min.(MΩ)	Capacitance (pF) @0.5V 1MHz	Leakage Current (μA) Min.@5V	Trigger Voltage (V) typ.	Clamping Voltage (V) typ.
MCE1012E 900FBP	90	0.60	300	10	200	0.10~0.70	1	400	50
•Meet IEC61000-4-2 level 4: Contact Discharge 8KV · Air Discharge 15KV									
Test Instru ments	•Agilent E4991A RF IMPEDANCE / MATERIAL ANALYZER •HP4338B MILLIONMMETER •Agilent E5071C ENA NETWORK ANALYZER •HP4285A PRECISION LCR METER •Agilent 4339B HIGH RESISTANCE METER •Keithley 2410 1100V SOURCE METER •Celestron TLP								

2. PART NUMBER CODE

MCE 1012 E 90 0 F B P
 1 2 3 4 5 6 7 8

- 1 : Series name
- 2 : Dimensions L*W
- 3 : Material code
- 4 : Impedance value (ex : 900=90Ω)
- 5 : Fixed decimal point
- 6 : Rated Current Code

A=50mA	B=80mA	C=100mA	D=150mA	E=200mA	F=300mA
G=400mA	H=500mA	I =600mA	J =700mA	K=800mA	

- 7 : Soldering: Green Parts: A— Soldering Lead-Free B— Lead-Free for whole chip
- 8 : Packaging: P – Embossed paper tape, 7”reel.

3. Typical Characteristic

MCE1012E900FBP

IMPEDANCE vs. FREQUENCY CHARACTERISTICS

INSERTION LOSS vs. FREQUENCY CHARACTERISTICS

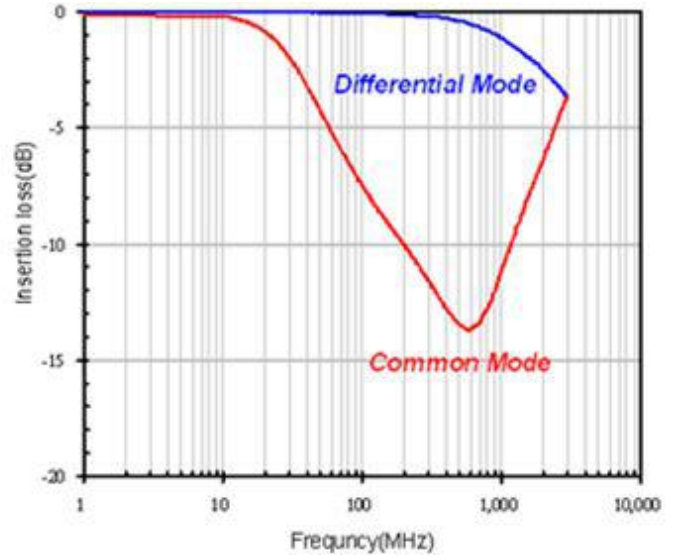
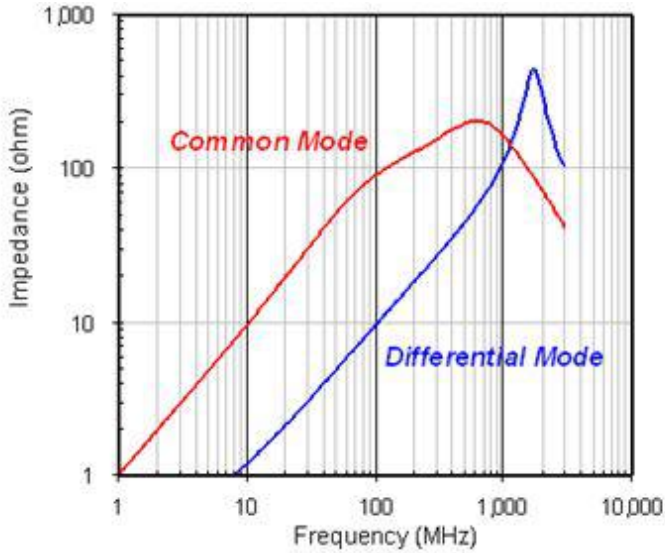

Eye pattern USB 2.0 high speed

ESD Wave forms

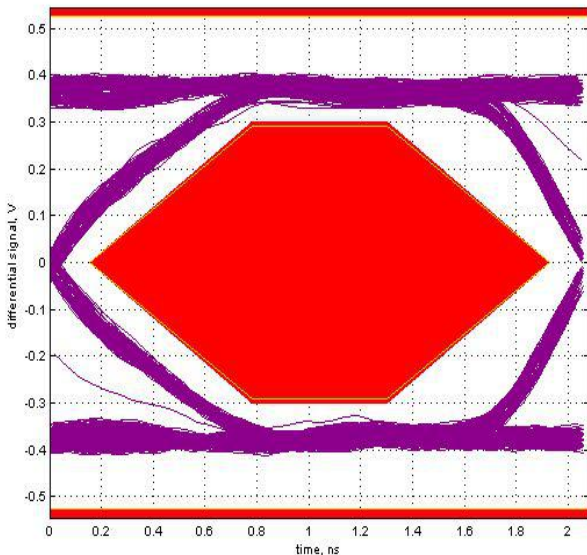

IEC 8KV_ESD Contact

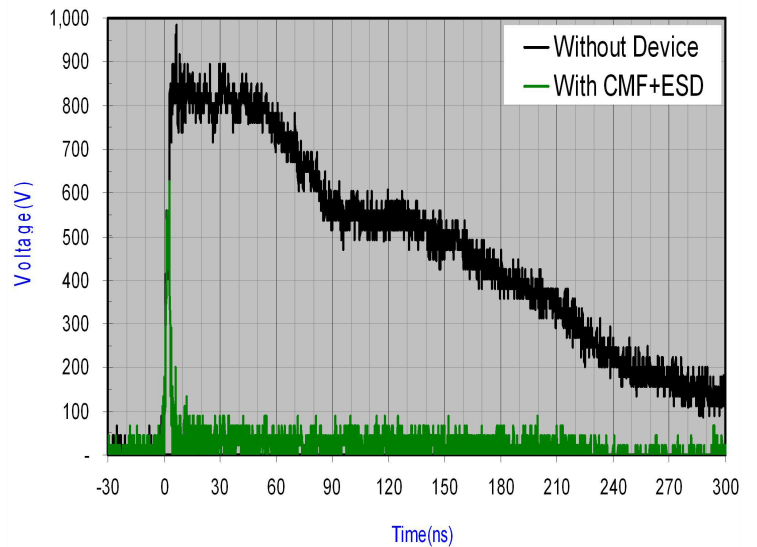

4. SHAPES AND DIMENSIONS

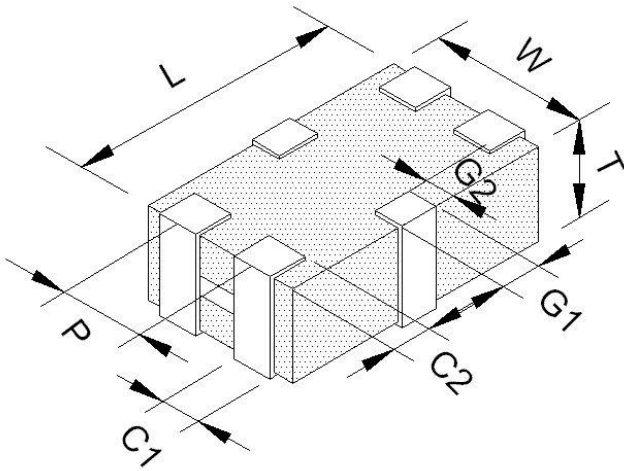

TYPE	Dimension
L	1.25±0.10
W	1.00±0.10
T	0.60±0.10
P	0.50±0.10
C1	0.30±0.10
C2	0.20±0.15
G1	0.30±0.15
G2	0.20±0.15
Unit : mm	

5. CIRCUIT CONFIGURATION & LAYOUT PAD

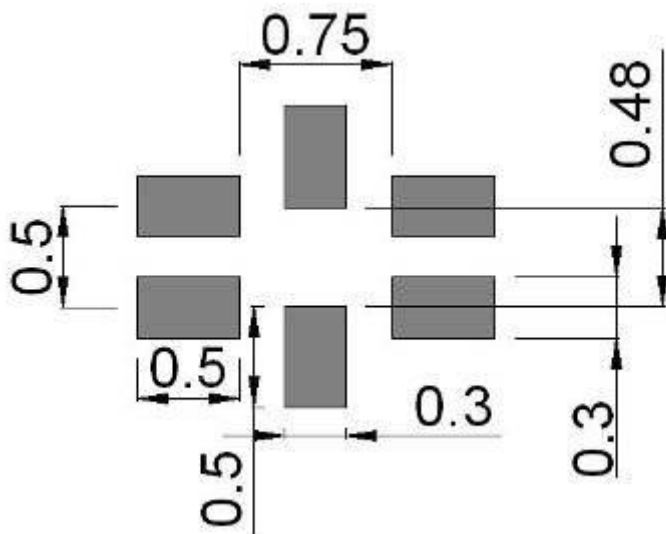
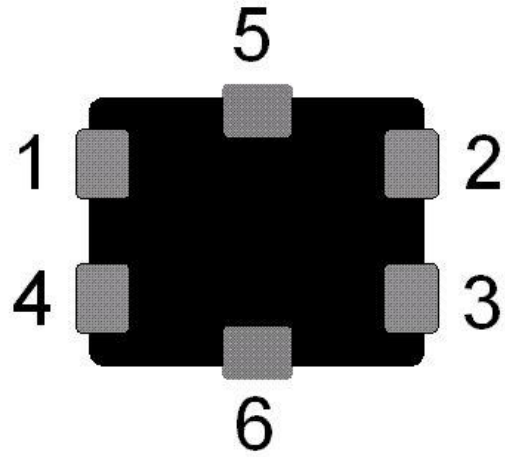
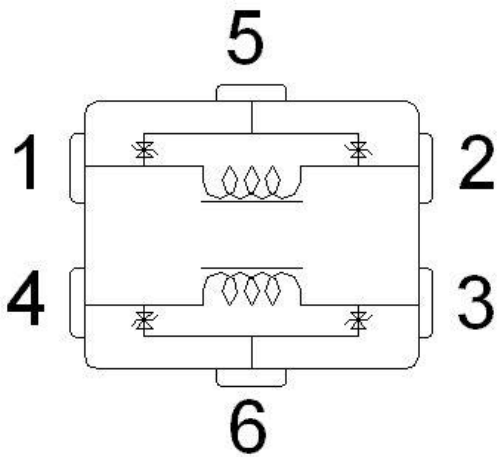

6. TAPE AND REEL SPECIFICATIONS/ TAPING DIMENSIONS

Type : Paper Carrier

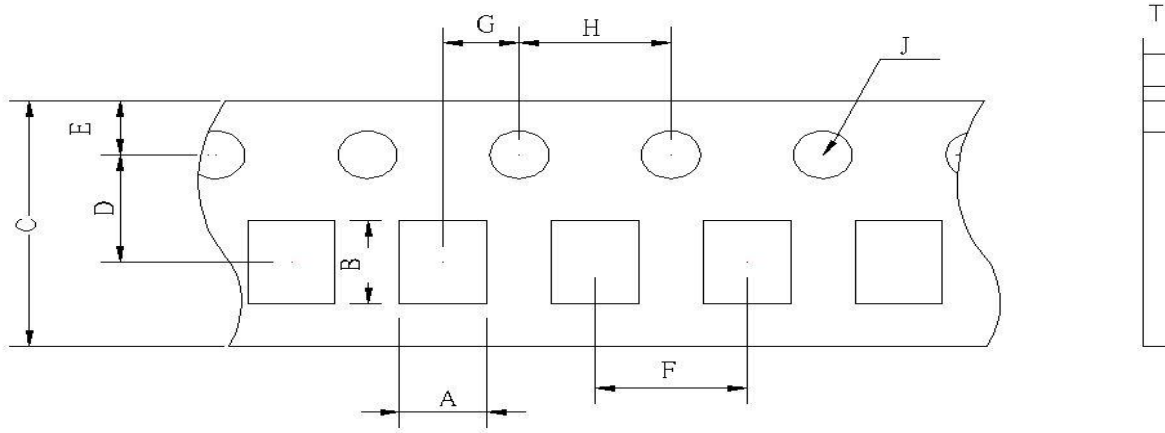

Unit: mm

Symbol	Size	Symbol	Size
C	8.00±0.10	H	4.00±0.10
D	3.50±0.05	J	Φ1.55±0.05
E	1.75±0.05	T	0.75±0.03
F	4.00±0.10	A	1.20±0.05
G	2.00±0.05	B	1.45±0.05

7. REEL DIMENSIONS

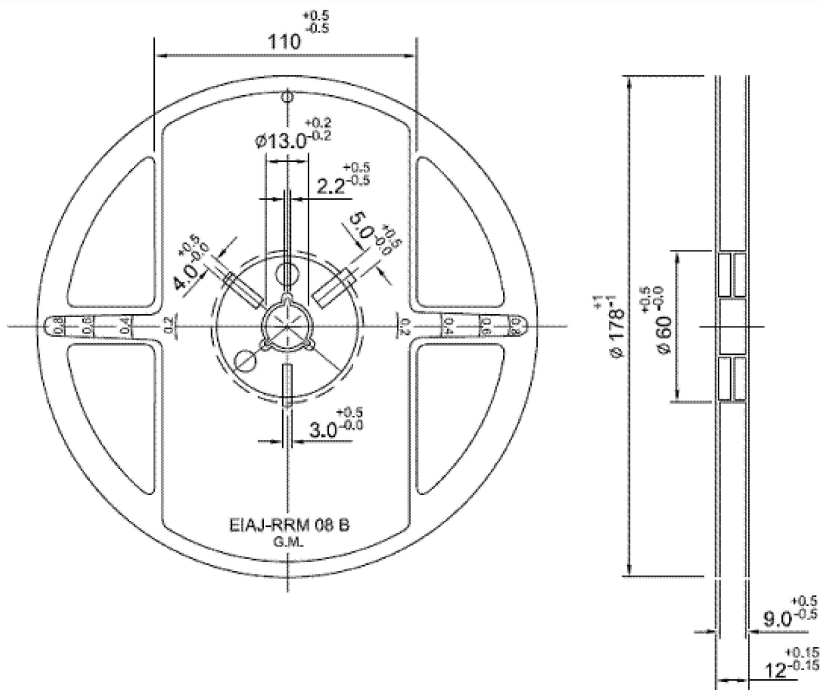

Unit: mm

8. STANDARD QUANTITY FOR PACKAGING

Packaging style : Taping

Reel packaging quantity : 4000 pcs/reel

Inner box : 5 reel/inner box

9. RECOMMENDED SOLDERING CONDITIONS

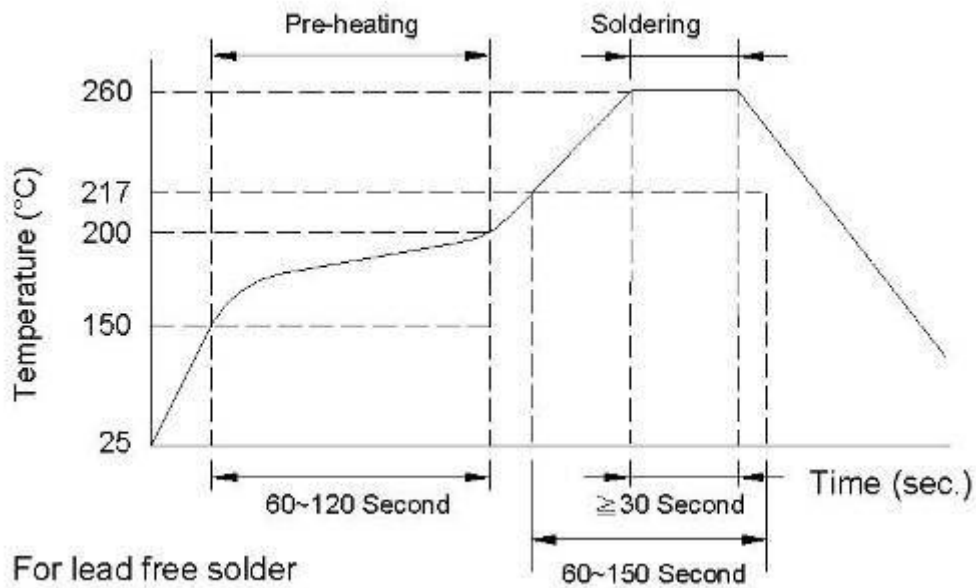

10. GENERAL TECHNICAL DATA

Operating temperature range : - 40°C ~ +85°C

Storage Condition : Less than 40°C and 70% RH

Storage Time: 6 months Max.

Soldering method: Reflow or Wave Soldering