

MCM 1012 B Series

Specification

Product Name	Chip Common Mode Filter
Series	MCM B Series Low Profile Type
Size	EIAJ 1012



MCM1012B SERIES LOW PROFILE TYPE (Chip Common Mode Filter) Engineering Specification

Features and Application

- Powerful components with composite co-fired material to solve EMI problem for high speed differential signal transmission line as USB, and LVDS, without distortion to high speed signal transmission.
- MIPI, MHL serial interface in mobile device.

1.PRODUCT DETAILS

Part No.	Imp. Com. (Ω) \pm 25% @100MHz	DCR Max. (Ω)	Rated Current Max.(mA)	Rated Voltage (V)	Withstand Voltage (V)	Insulation Resistance Min.(M Ω)
MCM1012B360F06BP	36	0.50	300	10	25	200
MCM1012B670F06BP	67	0.50	300	10	25	200
MCM1012B900F06BP	90	0.60	300	10	25	200
MCM1012B121F06BP	120	0.60	300	10	25	200
Test Instruments	<ul style="list-style-type: none"> •Agilent E4991A RF IMPEDANCE / MATERIAL ANALYZER •HP4338 MILLIOHMMETER •Agilent E5071C ENA SERIES NETWORK ANALYZER •Keithley 2410 1100V SOURCE METER 					

2.PART NUMBER CODE

MCM 1012 B 90 0 F 06 B P
 1 2 3 4 5 6 7 8 9

- 1 Series Name
- 2 Dimensions L*W
- 3 Material Code
- 4 Impedance(Ω) \pm 25% } (ex : 900=90 Ω)
- 5 Fixed Decimal Point }
- 6 Rated Current Code

A=50mA	B=80mA	C=100mA	D=150mA	E=200mA	F=300mA
G=400mA	H=500mA	I=600mA	J=700mA	K=800mA	

- 7 Dimensions T (ex : 06=0.60mm)
- 8 Soldering: Green Parts: A— Soldering Lead-Free B— Lead-Free for whole chip
- 9 Packaging: P – Embossed paper tape, 7”reel.

3.TYPICAL CHARACTERISTIC

MCM1012B360F06BP

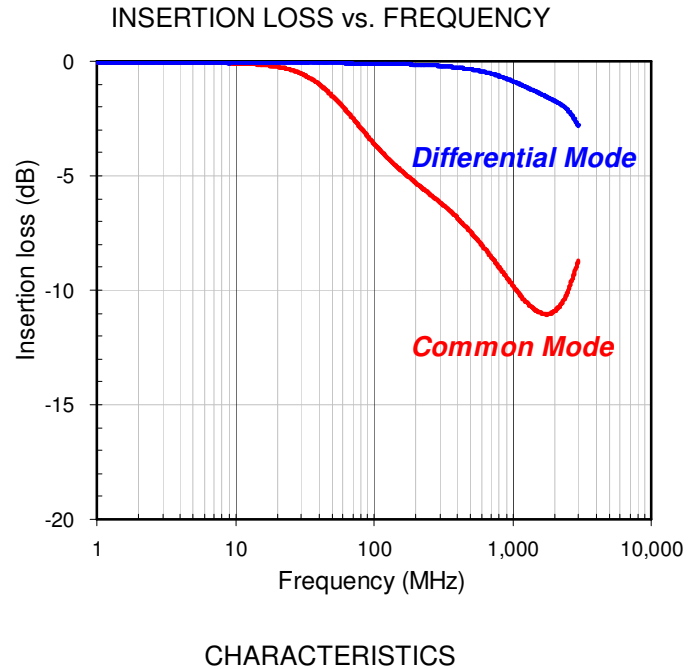
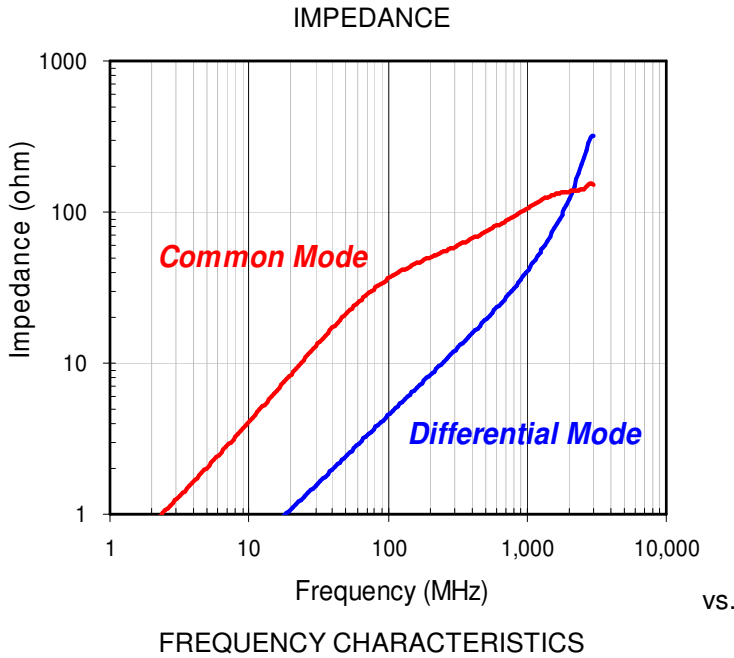

MCM1012B670F06BP

IMPEDANCE vs. FREQUENCY CHARACTERISTICS

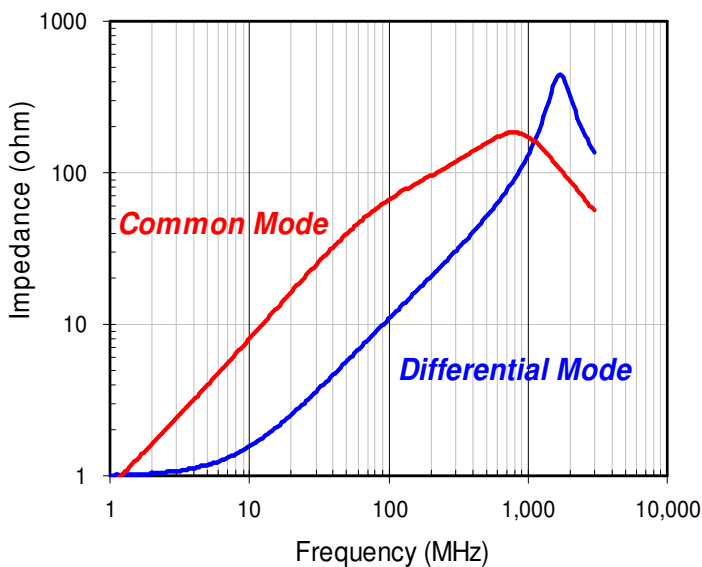

INSERTION LOSS vs. FREQUENCY CHARACTERISTICS

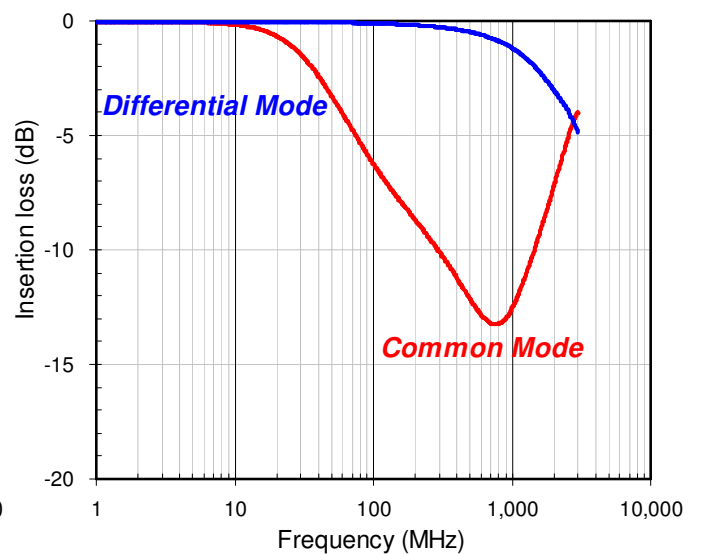

MCM1012B900F06BP

IMPEDANCE vs. FREQUENCY CHARACTERISTICS

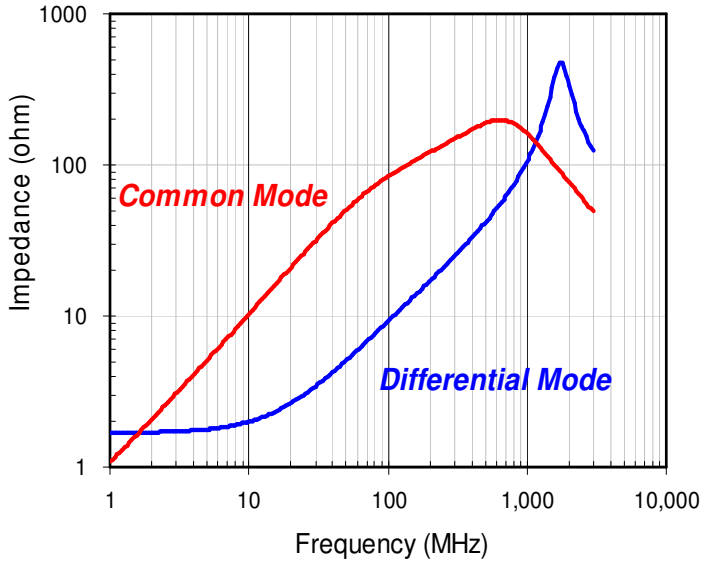

INSERTION LOSS vs. FREQUENCY CHARACTERISTICS

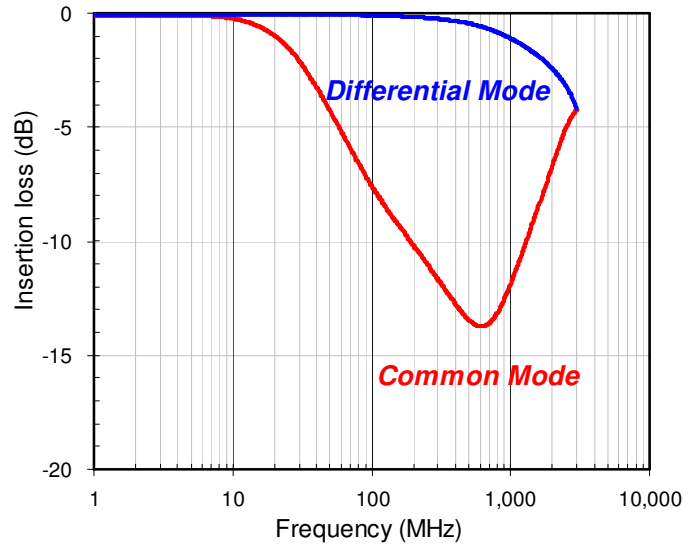

MCM1012B121F06BP

IMPEDANCE vs. FREQUENCY CHARACTERISTICS

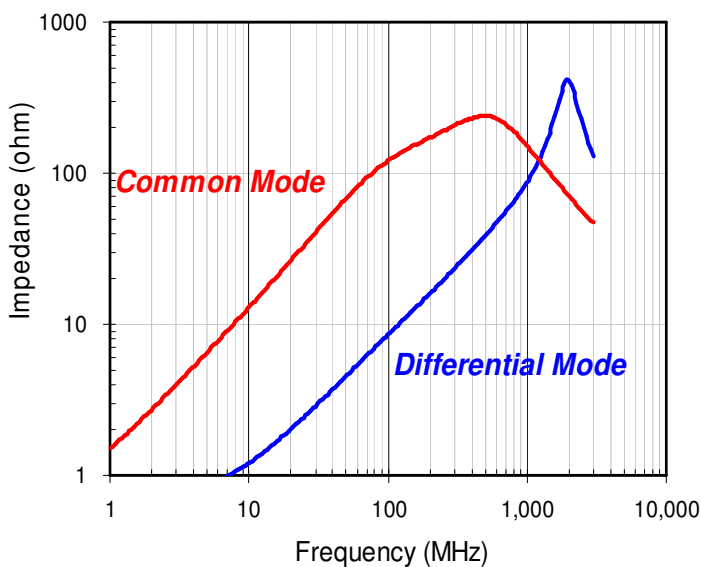

INSERTION LOSS vs. FREQUENCY CHARACTERISTICS

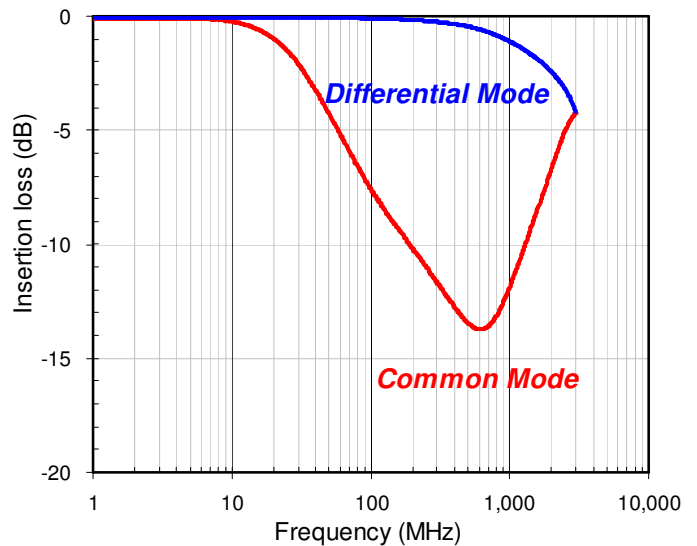

4.SHAPES AND DIMENSIONS

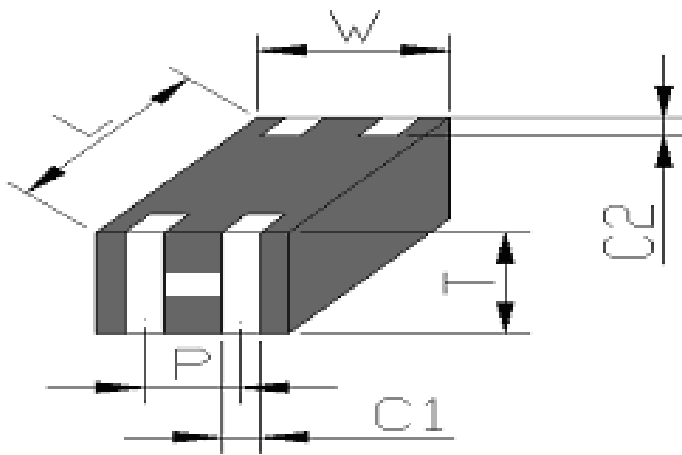

TYPE	1012
L	1.25±0.10
W	1.00±0.10
T	0.60±0.10
P	0.50±0.10
C1	0.30±0.10
C2	0.20±0.15
Unit: mm	

5.MEASURING CIRCUITS

(A):Common mode

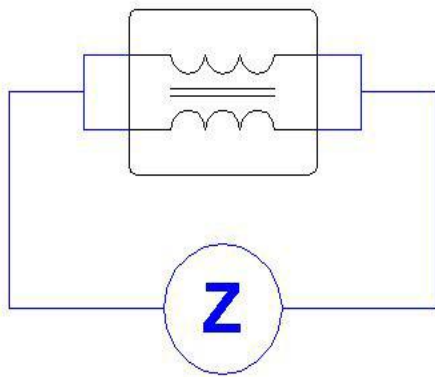

(B):Differential mode

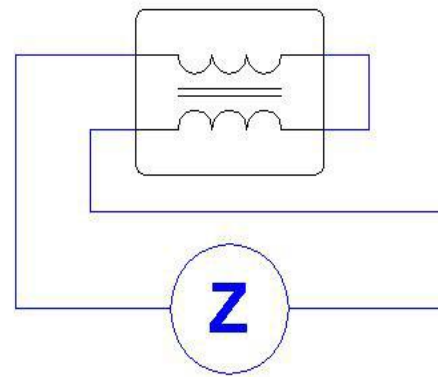

6. CIRCUIT CONFIGURATION & LAYOUT PAD

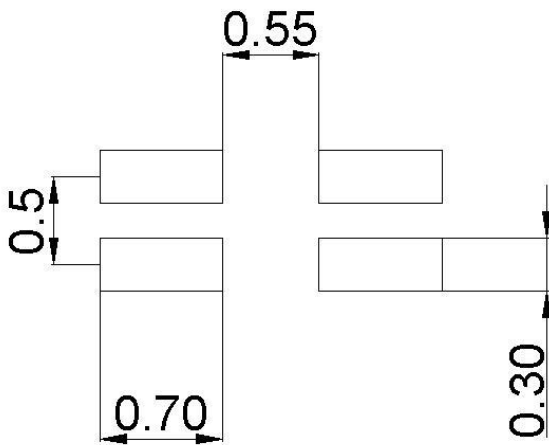
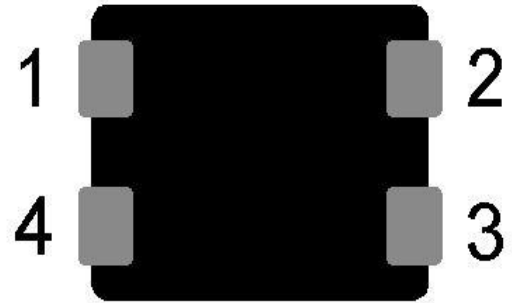
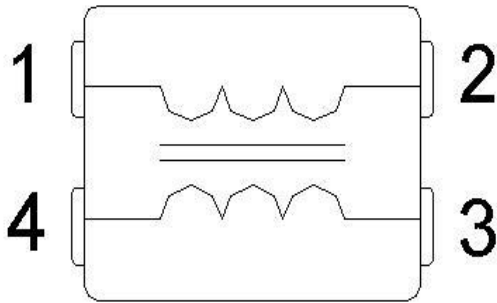

7. RECOMMENDED SOLDERING CONDITIONS

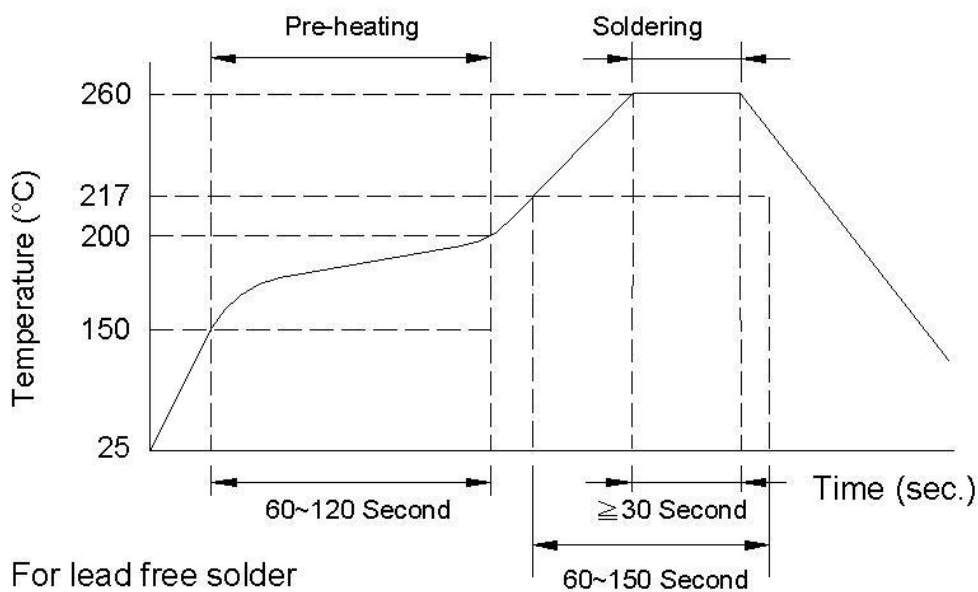

8.RELIABILITY AND TEST CONDITION

Test item	Test condition	Criteria
Temperature Cycle	A. Temperature : -40 ~ +85°C B. Cycle : 100 cycles C. Dwell time : 30minutes Measurement : at ambient temperature 24 hrs after test completion	A. No mechanical damage B. Impedance value should be within $\pm 20\%$ of the initial value
Operational Life	A. Temperature : 85°C $\pm 5^\circ\text{C}$ B. Test time : 1000 hrs C. Apply current : full rated current Measurement : at ambient temperature 24 hrs after test completion	A. No mechanical damage B. Impedance value should be within $\pm 20\%$ of the initial value
Biased Humidity	A. Temperature : 40 $\pm 2^\circ\text{C}$ B. Humidity : 90 ~ 95 % RH C. Test time : 1000 hrs D. Apply current : full rated current Measurement : at ambient temperature 24 hrs after test completion	A. No mechanical damage B. Impedance value should be within $\pm 20\%$ of the initial value
Resistance to Solder Heat	A. Solder temperature : 260 $\pm 5^\circ\text{C}$ B. Flux : Rosin C. DIP time : 10 ± 1 sec	A. More than 95 % of terminal electrode should be covered with new solder B. No mechanical damage C. Impedance value should be within $\pm 20\%$ of the initial value

<p>Steam Aging Test</p>	<p>A. Temperature : $93 \pm 2^{\circ}\text{C}$ B. Test time : 4 hrs(MCA) Others : 8 hrs C. Solder temperature : $235 \pm 5^{\circ}\text{C}$ D. Flux : Rosin E. DIP time : 5 ± 1 sec</p>	<p>More than 95 % of terminal electrode should be covered with new solder</p>
------------------------------------	--	---

9.TAPE AND REEL SPECIFICATIONS

Type : Paper Carrier

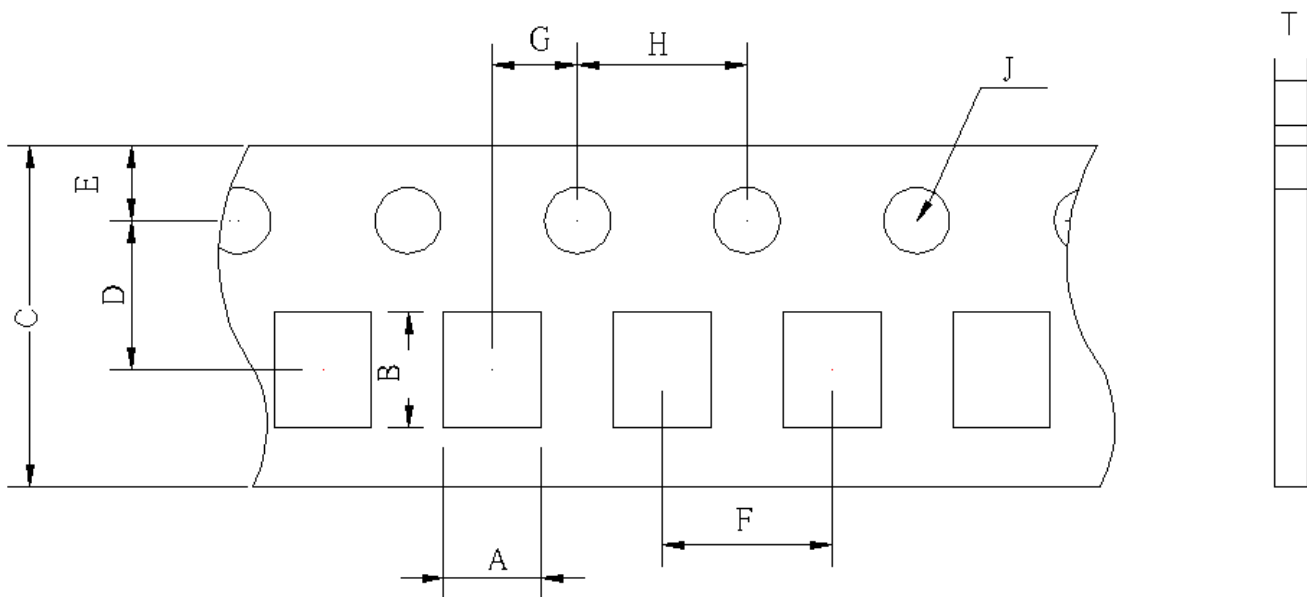

Unit : mm

Symbol	Size	Symbol	Size
C	8.00 ± 0.10	H	4.00 ± 0.10
D	3.50 ± 0.05	J	$\Phi 1.55 \pm 0.05$
E	1.75 ± 0.05	T	0.75 ± 0.03
F	4.00 ± 0.10	A	1.20 ± 0.05
G	2.00 ± 0.05	B	1.45 ± 0.05

10. REEL DIMENSIONS

Unit: mm

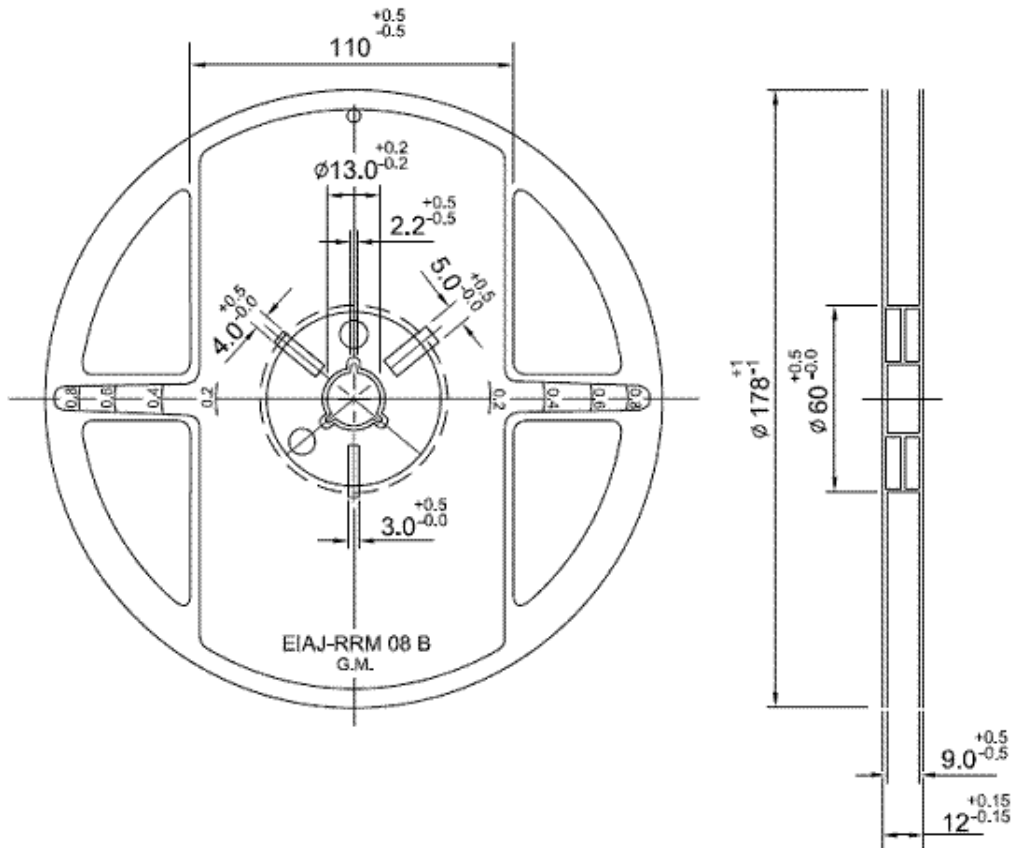

11. STANDARD QUANTITY FOR PACKAGING

Packaging style : Taping

Reel packaging quantity : 4000 pcs/reel

Inner box : 5 reel/inner box

12. GENERAL TECHNICAL DATA

Operating temperature range : - 40°C ~ +85°C

Storage temperature : 40°C Max., 70%RH Max.

Storage Time: 6 months Max.

Soldering method: Reflow or Wave Soldering